

**MITSUBISHI**  
**FORKLIFT TRUCKS**

---

# SERVICE MANUAL

**Diesel Engine**  
**S6S**

**FD35 thru FD50**  
**FD60 and FD70**

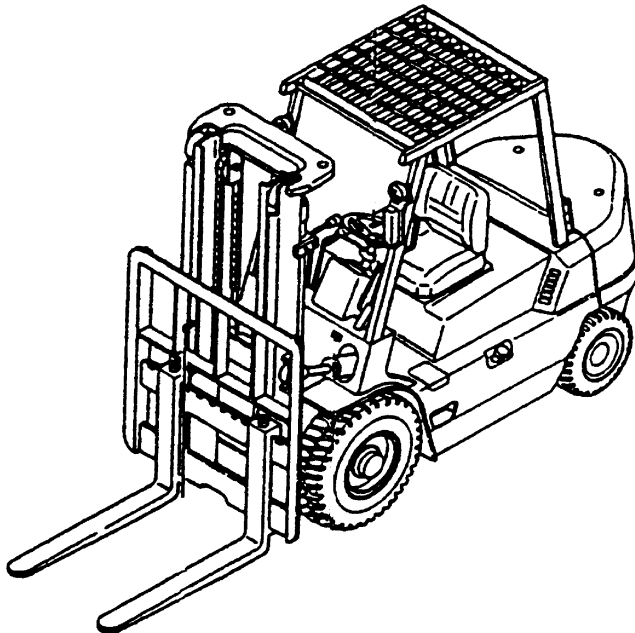

**Quality Makes the Difference**

**99709-56110**



## INTRODUCTION



This publication covers the Mitsubishi S6S diesel engine. The information, specifications, and illustrations in this publication are on the basis of information that was current at the time this issue was written.

The fuel injection pump and governor are described in the separate volumes of this publication.

The sections and their contents will be found in TABLE OF CONTENTS and the contents of each section in the first page of the section.

### 1. How To Use This Manual

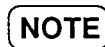
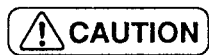
- (1) The parts read in the texts or shown in the illustrations are numbered in the disassembly sequence prescribed for each system or assembly.
- (2) What to be inspected for during disassembly are indicated in  in the disassembled view.
- (3) The maintenance standards to be referred to for inspection and repairs are indicated in easy-to-refer passages of the texts and also in Section 2 in a tabulated form.
- (4) Some marks are used in this manual to emphasize important and critical instructions as shown below:

	.....	Procedures, conditions, etc. which it is essential to highlight.
	.....	Procedures, practices, etc. which will result in damage to or destruction of engine if not strictly observed.
	.....	Procedures, practices, etc. which will result in personal injury or loss of life if not correctly followed.

- (5) Tightening torque in “wet” condition is indicated as [wet]. Unless indicated as such, the torque is to be considered in “dry” condition.

## 2. Glossary

**NOMINAL SIZE** is the named size which has no specified limits of accuracy.

**ASSEMBLY STANDARD** is the dimension of a part to be attained at the time of assembly or the standard performance. Its value is rounded to the nearest whole number needed for inspection and is different from the design value.

**STANDARD CLEARANCE** is the clearance to be obtained between mating parts at the time of reassembly.

**REPAIR LIMIT** is the maximum or minimum dimension specified for a part. A part which has reached this limit must be repaired.

**SERVICE LIMIT** is the maximum or minimum dimension specified for a part. A part which has reached this limit must be replaced.

## TABLE OF CONTENTS

Section	Contents	No.
General information	Typical engine arrangements; location of engine serial number; specifications; suggestions for disassembly and assembly	1
Maintenance standards	Maintenance standards; tightening torques; sealants	2
Special tools	Special tool list	3
Overhaul instructions	Determining when to overhaul the engine; measuring the compression pressure	4
Testing and adjusting	Testing and adjusting; dynamometer test; performance test	5
Engine accessory removal and installation	Removal and installation Fuel injection pump, alternator, water pump, starter, etc.	6
Engine proper	Disassembly, inspection and assembly Cylinder head and valve mechanism; flywheel; damper, timing gears and camshaft; pistons, connecting rods, crankshaft, crankcase and tappets	7
Air inlet and exhaust systems	Exhaust manifold inspection	8
Lubrication system	Disassembly, inspection and assembly Oil pump; oil filter; oil pressure relief valve	9
Cooling system	Disassembly, inspection and assembly Water pump; thermostat	10
Fuel system	Disassembly, inspection and assembly Fuel filter; injection nozzles	11
Electrical system	Disassembly, inspection and assembly Starter; alternators; glow plugs	12
Workshop theory	Basic recommended assembly procedures Oil seals; O-rings; bearings; split pins and spring pins	13

**1**

**2**

**3**

**4**

**5**

**6**

**7**

**8**

**9**

**10**

**11**

**12**

**13**